

Conversion of spring pivot bolt from 30mm to 24mm diameter on the Airlight II air suspension system.

Background

As part of the introduction of the new products into series production, the spring pivot bolt connection on all Airlight II air suspensions will be changed from M 30 to M 24 from November 2007 onwards. Introducing a M 24 pivot bolt provides greater security due to higher bolt tension being achieved. In addition the surface of the clamped interfaces is increased. This means the bolted connection has been made even less susceptible to settling.

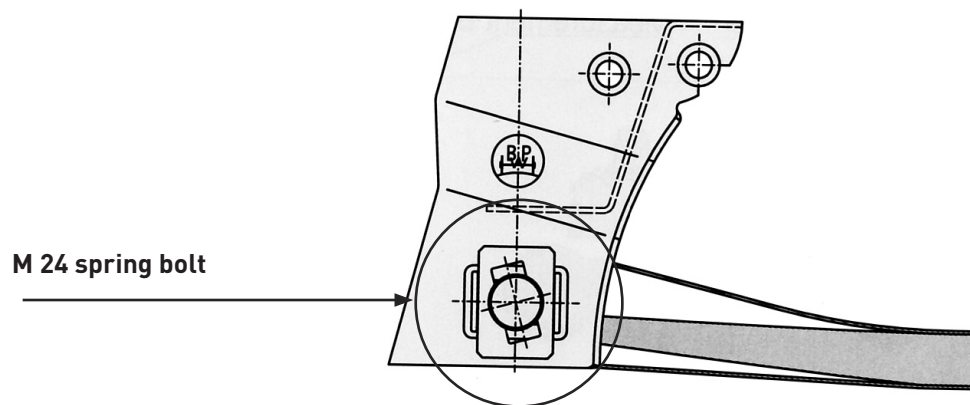

Technical Features

The adaptation to M 24 spring bolts is performed by changing the spring pivot bolt assemblies, the bushes in the air suspension hanger brackets and the steel/rubber/steel bushes in the trailing arms. The geometry of the actual trailing arm is not changed. It is possible to adapt from the M 30 spring bolt to the M 24 spring bolt simply by changing the steel/rubber/steel bush.

The changeover to the M 24 spring bolt means the spanner width required for the nut changes from 46mm (for M 30 spring bolt) to 36mm (for M 24 spring bolt).

The tightening torque (with a torque wrench) for Airlight II hanger brackets is reduced from 900Nm (880 - 990Nm) for the M 30 spring bolt to **650Nm (605-715Nm) for the M 24 spring bolt**. If the M 24 spring bolt is torqued to 900Nm it will break.

Please contact **Stephen du Toit** on (082) 901-2639 or **Zehraan Rassool** on (082) 901-5327 for assistance.



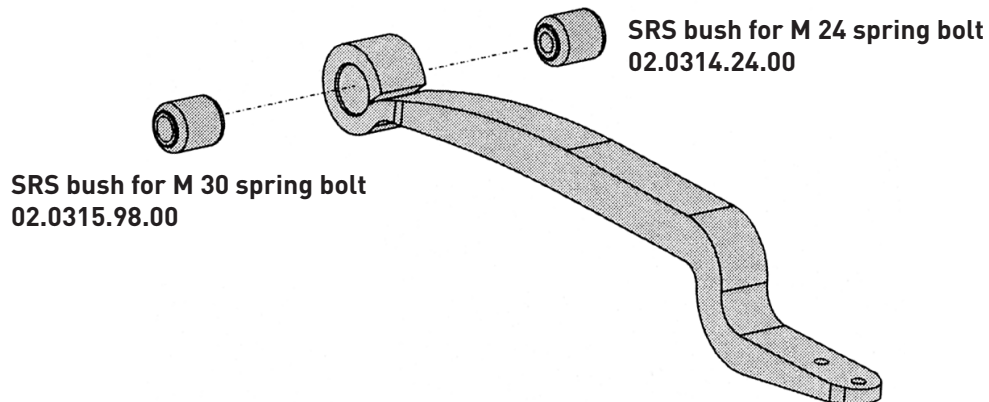

Once the spring bolt is correctly torqued after wheel alignment there is no need to re-torque the bolt after the first trip under loaded conditions.

For new trailers, hanger brackets with M 30 spring bolts are not allowed to be combined with M 24 spring bolts on the same trailer! For repairs it will be acceptable to mix hangers on a trailer as long as both hangers on the same axle are the same size pivot bolt (Do not put a M 24 on the left and a M 30 on the right).

Warning note for start of new series production

At the start of series production, all modules for M 24 spring bolts will be identified with a note on the trailing arm.

Please contact **Stephen du Toit** on (082) 901-2639 or **Zehraan Rassool** on (082) 901-5327 for assistance.



BPW Axles (Pty) Ltd • P.O. Box 82545 • Southdale 2135 • South Africa • Tel (011) 680-1443/680-1493, 681-3300 • Fax (011) 680-1829
E-mail: sales@bpwaxles.co.za • Website: www.bpw.co.za