

Shock absorber fastening:

M 24 M = **420 Nm** (390 - 460 Nm)
for aluminium hanger brackets:
M 24 M = **320 Nm** (300 - 350 Nm)

Bolted connection, air suspension hanger bracket (steel) to longitudinal chassis beam (steel):

M 16 M = **260 Nm** (240 - 285 Nm)

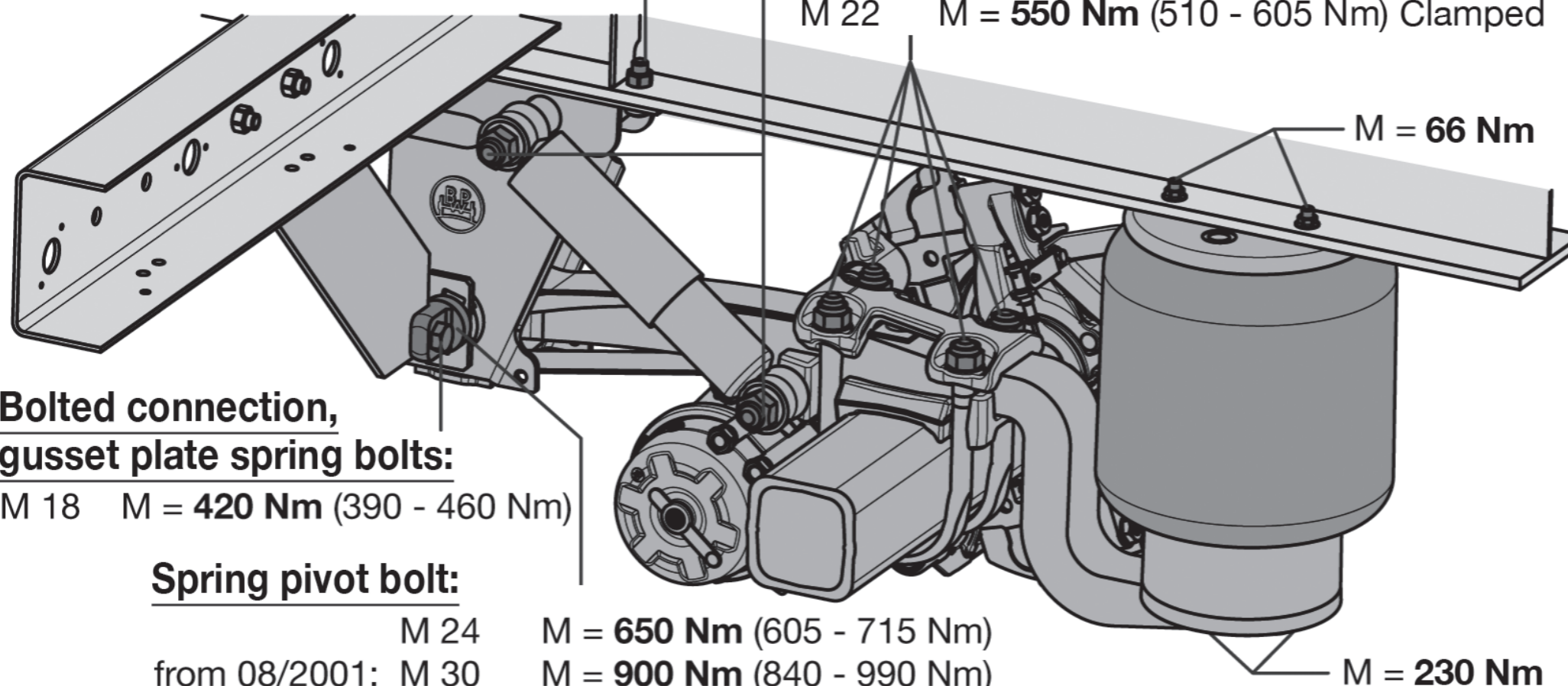

Drum and Disc brake booster connection:

M16 M = **210 Nm**

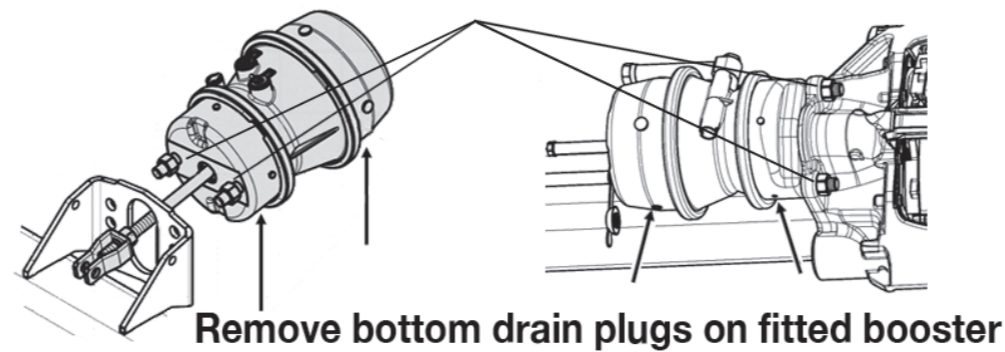

Spring U-bolt:

M 24 M = **650 Nm** (605 - 715 Nm) Welded
M 22 M = **550 Nm** (510 - 605 Nm) Clamped

Single-sided lift:

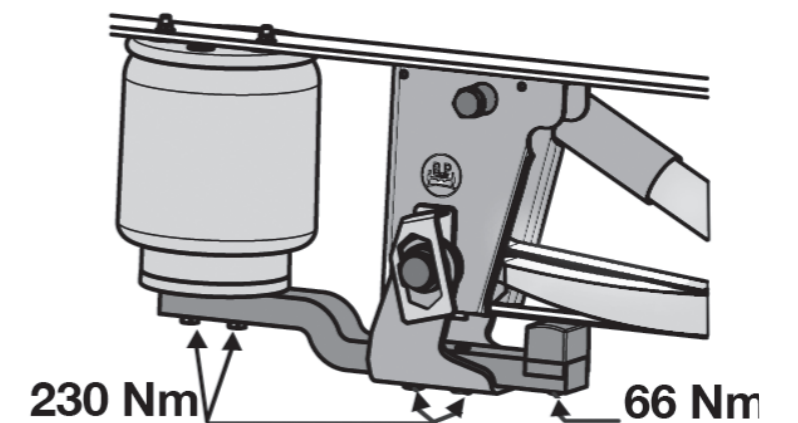

Two-sided lift:

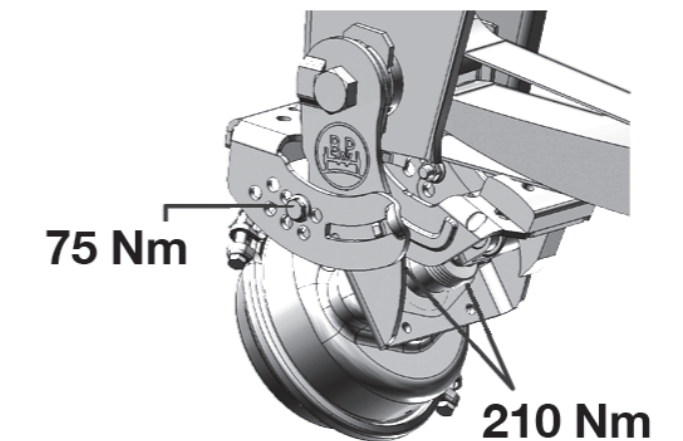

Bolted connection, gusset plate spring bolts:

M 18 M = **420 Nm** (390 - 460 Nm)

Spring pivot bolt:

M 24 M = **650 Nm** (605 - 715 Nm)
from 08/2001: M 30 M = **900 Nm** (840 - 990 Nm)

*Tack welding of adjustment plates required

Bolt-on double-sided lift:

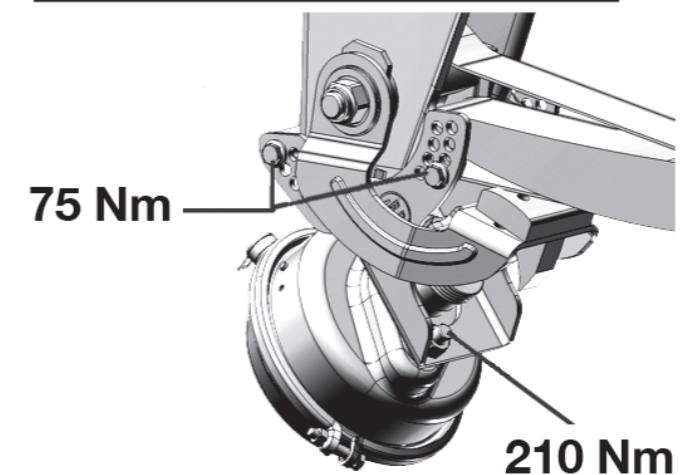

Refer to the valid installation instructions and maintenance regulations for the current tightening torques!

Tel (011) 681-3300 • (011) 680-1443 • E-mail: bpwsales@bpw.co.za • Website: www.bpw.co.za