



Guidelines for inspection and servicing

Couplings

2022

General information

General information

The components used to couple vehicles and trailers are exposed to very high stress, even during normal use. Regular service and maintenance is a prerequisite if the coupling is to function well for the duration of its service life.

The length of the service interval depends on the type of trailer, loads, road and climatic conditions, etc. The service should ideally be carried out in conjunction with other inspection of the vehicle, e.g. every 60,000 or 90,000 km.

If daily inspection or safety checks show that any of the wear limits have been exceeded or that the function of the product has been impaired, servicing must be carried out immediately.

If any of the product's wear limits have been exceeded, this is an indication that other parts also require servicing.

Check that all type plates and warning/information labels are legible and have not been painted over, washed off or otherwise damaged. Illegible labels must be replaced and can be ordered from VBG Truck Equipment GMBH.

If the coupling is damaged as a result of jackknifing, off-road driving or reversing, the vehicle must be stopped and the coupling replaced.

NB! All coupling equipment must be depressurised and de-energised before servicing is carried out. This means that you must disconnect the air supply and power to actuator-assisted couplings.

Always follow the vehicle manufacturer's bodybuilding instructions.

Guidelines for inspection and servicing Couplings 2022

© VBG GROUP TRUCK EQUIPMENT GMBH

11/2022 - Id. -Nr. 10090734a

The content of this publication may not be reproduced either in full or in part without the prior approval of VBG GROUP TRUCK EQUIPMENT GMBH.

This prohibition is applicable for all forms of reproductions in all types of media, including electronic media.

Explanation of symbols



Warning!

Never put your fingers into the coupling mouth as they may be crushed. An open coupling always involves a risk of crushing due to the powerful springs that constitute the coupling's closing function.



Severity

3 = STOP to ensure future use.

2 = Rectify as soon as possible, within four weeks.

1 = Rectify when able or during next service. Within no more than one year.

General information on couplings	4
Couplings with V and Dc values/with only D value.	10
Coupling.....	26
Remote indication	30
Air assisted coupling	32
Control kit for AM/Specific coupling jaw and coupling model.....	34

Checkpoint	Symptom	Fault
<p>Complete coupling.</p> 	<p>Broken signal pin. Deformed coupling mouth, handle etc. The coupling is askew and bent. The coupling turns when there is no drawbar connected. The coupling bolt does not engage. The signal pin jams. The coupling rattles. The trailer/centre-axle trailer jolts, "winds". The coupling bolt is not triggered during connection.</p>	<p>The signal pin does not indicate the correct position. Rear-end collision handles, etc. Cracked, deformed coupling mouth. Bent horizontal bolt. Loose drawbeam sleeve bolts. Worn rubber elements. The castellated nut's protective cover is missing. The castellated nut's locking device is incorrectly fitted/damaged/missing. The coupling bolt does not assume a locked and secure position during connection. The coupling bolt/bushings is/are worn out. The locking pin jams. The wear plates are worn out. Loose coupling mouth. Loose handle.</p>
<p>Complete coupling.</p>	<p>May be noise or play during use of the coupling. Connection and disconnection does not work fully.</p>	<p>Loose bolted joints such as those between the drawbeam/drawbeam sleeve, coupling mouth/jaw, wear plate/coupling mouth.</p>

Inspection method	Requirements, wear limits, etc.	Instructions for rectification
<p>Visually check, take simple readings and operate coupling. Inspect function, attachment, damage, wear. Measurements are taken to determine wear to, among other things, the bolt and bushings. Functional check of the coupling's control and locking device by moving the coupling into the open position and into the locked position using a drawbar eye and by pulling the coupling bolt up using tools. First and second locking are included in the locking device. Any damage to the horizontal bolt caused by worn bushings in the drawbeam sleeve or cavities after variation of current between the vehicle and trailer must be measured. Check that the coupling can rotate in its attachment to the drawbeam.</p>	<p>Information on the coupling's labels, signs location, performance, spare parts, driver manuals, assembly instructions, space requirements, etc. can be found on Ringfeder's website. Information on important daily inspection/maintenance that can be performed without workshop equipment and the coupling's function is included in the "Driver's Manual" available on the Ringfeder website.</p> <p>Examples of important requirements. If the coupling is damaged due to e.g. jackknifing, off-road driving or reversing, the vehicle must be stopped and the coupling replaced. The coupling equipment must be equipped with warning and information labels. Welding, drilling or otherwise modifying the coupling is not permitted. Wear limits, see specific coupling model. The coupling must be able to rotate in its attachment $\pm 25^\circ$, torque 100–1,000 Nm. When the coupling is in the locked position, the signal pin must be level with the mechanism housing; if the coupling is remote-controlled, there must also be a separate indicator that shows a green coupling symbol when the coupling is closed and locked. When the coupling is open, the signal pin must protrude approx. 10 mm out of the mechanism; if the coupling is remote-controlled, there must also be a separate indicator that shows red coupling symbol. When the coupling is in the locked position, it must be possible to push the coupling bolt up 0–5 mm.</p>	
<p>Visual check of the attachment, damage and discolouration of rust-coloured water near the joint surfaces. Torque-tighten the bolts if you suspect low tension.</p>	<p>No movement is permitted and there should be no rotation during test-tightening to the prescribed tightening torque; see installation instructions for each coupling model.</p>	<p> In the event of any movement or too low a tightening torque, the parts should be dismantled and checked. If there is any visible damage, these parts must be replaced. When the components have been dismantled, they must be re-tightened after driving 2,500 km.</p> <p>① ② ③</p> <p>②</p>

Checkpoint	Symptom	Fault
<p>Complete coupling.</p>	<p>The coupling is bent to the side, up or down. The coupling mouth is bent, signs of jackknifing, etc.</p>	<p>Deformation of horizontal bolt/coupling jaw or other load-carrying part.</p>
<p>Complete coupling.</p>	<p>Narrow rust-coloured streaks, cracks in the paint/paint is peeling.</p>	<p>Cracks.</p>
<p>The coupling bolt's wear area.</p>	<p>The coupling bolt moves up and down slightly when the traction vehicle pushes and pulls at the drawbar. The coupling bolt's wear/marks from the eye are below the coupling bolt's biggest diameter. The coupling bolt's wear/marks from the eye are below and above the coupling bolt's biggest diameter. Quick wear, which leads to play between the vehicle and trailer; constant jolting between the vehicle and trailer may occur.</p>	<p>The coupling bolt's wear/eye marks are incorrectly positioned on the coupling bolt (not centred over the "coupling bolt's wear surface for the eye") due to worn wear plate and/or incorrect drawbar height for coupling.</p>

Inspection method

Visual check of centring around the coupling's centreline in vehicle direction and functional test.
Dismantling and measuring in the event of jackknifing damage.

Requirements, wear limits, etc.

No deformations permitted. Deviations of more than 1 mm from the original position are defined as deformations. In the event of deviation of 1 mm or more, driving with a trailer is not permitted.
However, max. 0.5 mm for the horizontal bolt; see checkpoint "Coupling jaw for fixed drawbar".

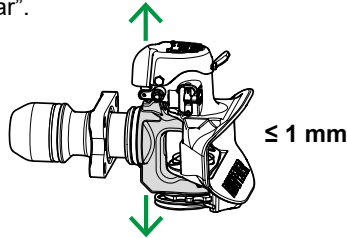

Instructions for rectification



Load-bearing components with deformations measuring 1 mm or more from their original position must be replaced and driving stopped.

③

To be checked visually, corners, radius transitions, holes, bolted joints, welded joints, etc. The surfaces must be dry and well cleaned.

No cracks are permitted.

Driving must be stopped immediately; cracked parts must always be replaced.

Observe any vertical movement of the coupling bolt when the vehicle pushes and pulls at the braked trailer.
Check the coupling bolt's wear pattern. Picture 1, green field in the middle displays the correct wear amount.
Picture 2, red field indicates a drawbar eye that is too low due to a worn wear plate.
Picture 3 shows a drawbar that is connected at the wrong height relative to the coupling, i.e. wear both above and below the coupling bolt's green field.

There must be no vertical movement of the coupling bolt when the vehicle is pulling and pushing at the braked trailer. There should be no wear outside the minimum diameters specified in the table below.



If the wear on the bolt is too low or the wear plate's minimum height is indicated, it must be replaced.
When the wear to the eye for the bolt is too great, the drawbar's balancing force will be reduced; the eye must rest firmly in the coupling mouth.

①

$40 \text{ mm} \geq 36,5 \text{ mm}$
 $50 \text{ mm} \geq 46,5 \text{ mm}$

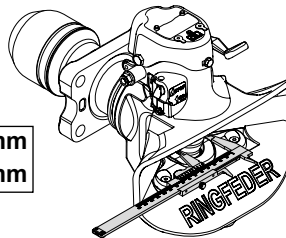

If the wear looks like it does on coupling bolt no. 3, the drawbar is at the incorrect height relative to the coupling, in which case its attachments should be rebuilt; the drawbar should be horizontal in the operating position.

①

$40 \text{ mm} \leq 2,5 \text{ mm}$
 $50 \text{ mm} \leq 2,5 \text{ mm}$

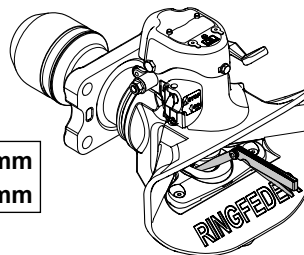

If the bolt is outside of the specified limits in terms of the smallest diameter, the mechanism must be replaced.

②

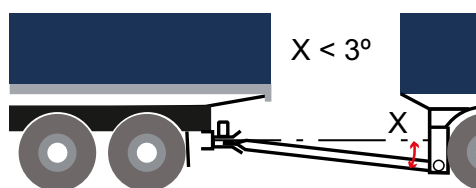
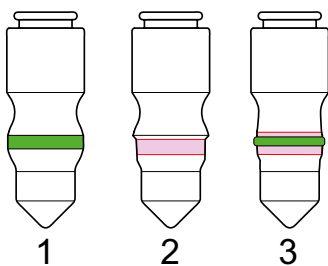

The drawbar angle should be less than 3°.

Checkpoint	Symptom	Fault
<p>The coupling bolt's and drawbar eyes wear area.</p>	<p>Quick wear, which leads to play between the vehicle and trailer; constant vibrations between the vehicle and trailer may occur.</p>	<p>The coupling bolt wears out quickly. Significant total play between the vehicle and trailer because the eye's wear ring/ bushing is worn and/or the coupling bolt and its bushings are worn.</p>
<p>The coupling bolt's wear area.</p>	<p>"Rattling" sound from the drawbar eye/ coupling. Quick wear, which leads to play between the vehicle and trailer; constant vibration between the vehicle and trailer may occur.</p>	<p>Worn coupling bolt. Incorrectly height of drawbar.</p>

Inspection method

Visually check the drawbar eye's wear ring/bushing and measure the diameter of the wear ring/bushing.
Visually check the coupling bolt and the upper/lower jaw bushing and measure each diameter.

Requirements, wear limits, etc.

All measured diameters must be within the limits specified below.

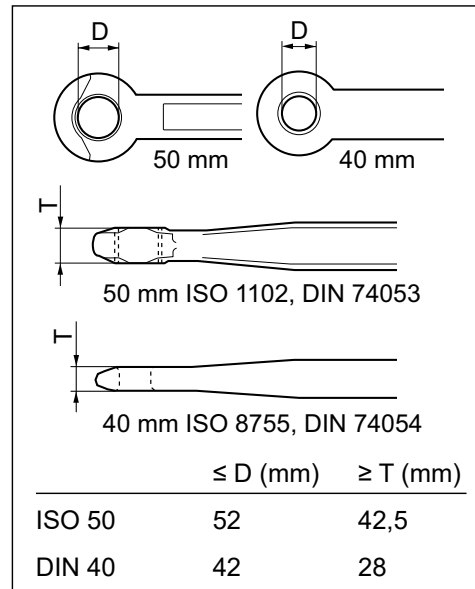

Instructions for rectification



Replace components outside of the specified max./min. dimensions.

2

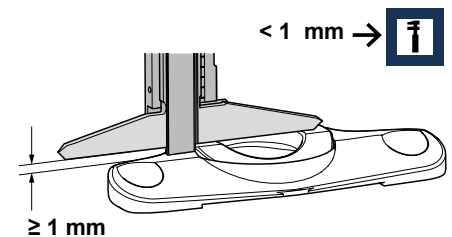
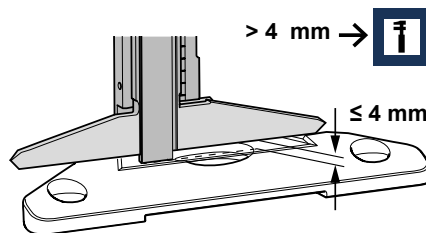
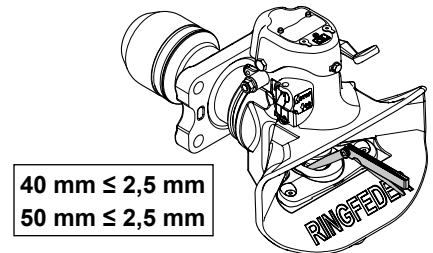
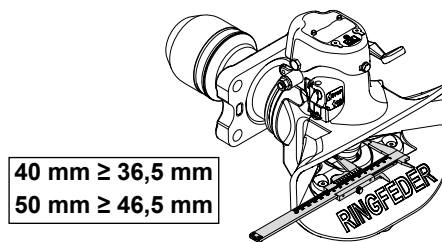

Estimate the support load of a fixed drawbar or from an articulated drawbar.

Fixed drawbar:
Support load up to 1000 kg with max V-value see type plate

Hinged drawbar:
Support load 100–500 N (10-50 kg)



If necessary, the support load must be adjusted.

1



Checkpoint	Symptom	Fault
<p>Coupling jaw for fixed and/or hinged drawbars.</p>	<p>Askew in the attachment, vertical and/or lateral deformation, damaged/broken coupling mouth. Damaged surrounding equipment such as endplates, beams and coupling mouth. Suspicion of reversing, off-road driving, jackknifing, etc. Other symptoms may include differences in the build-up of dust and residual rubber on the contact surfaces between rubber elements and the coupling jaw.</p>	<p>Bent horizontal bolt and/or cracks in the horizontal bolt.</p>
<p>Coupling jaw for fixed and/or hinged drawbars.</p>	<p>Reduced comfort, more noise and more noticeable jolting during driving.</p>	<p>Coupling jaw stuck with rust or deformation. Cannot be rotated.</p>
<p>Coupling jaw for fixed and/or hinged drawbars.</p>	<p>The coupling will rotate when no trailer is connected. Difficult to connect.</p>	<p>The coupling jaw rotates too easily.</p>

Inspection method

Dismantle the coupling jaw. Measure the perpendicular alignment between the coupling jaw's circular part (the rubber element's contact surface) and the horizontal bolt, see picture.

Visually check that the horizontal bolt does not have cracks in the radius transition against the rubber element's contact surface.

Check other surrounding equipment such as endplates, drawbeam and underrun protection etc.

Requirements, wear limits, etc.

The horizontal bolt must be perpendicular to the coupling jaw's circular part for 0.5 mm of the horizontal bolt's length. No cracks are allowed.

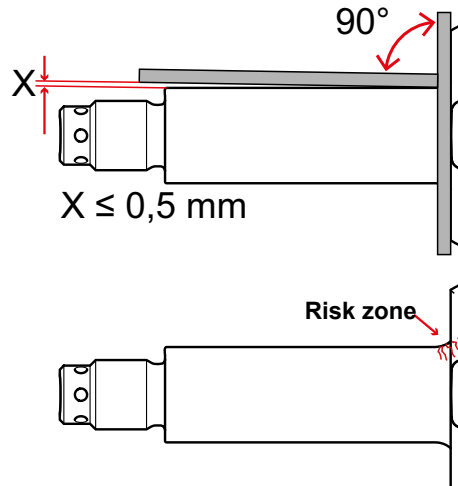

Instructions for rectification



If there are cracks, replace the coupling. In the event of deviation greater than 0.5 mm, replace the coupling.

3

Rotate the coupling by inserting a rod through the coupling mouth. Length 1 m, power 1 kN.

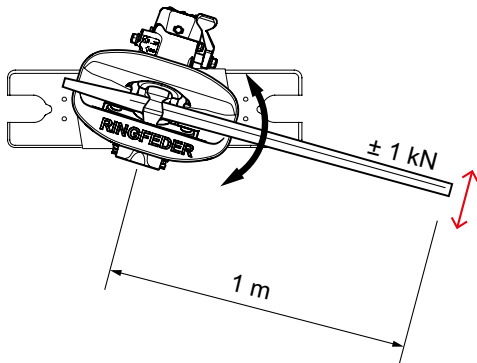

The coupling should rotate at 1,000 Nm.



If the coupling jaw is stuck, it must be removed from the drawbeam sleeve. Clean the horizontal bolt and the drawbeam sleeve.

2

In the event of worn bearings, replace bushings including rubber elements.



In the event of a damaged horizontal bolt, replace the coupling jaw.

If the drawbeam sleeve is damaged, it must be replaced.

3

Visual check of rubber elements. Must not be easy to rotate by hand.

Minimum torque for rotation 100 Nm.



In the event of worn bearings, replace bushings including rubber elements.

2

Coupling



Couplings with V and Dc values



Couplings with only D value

Checkpoint	Symptom	Fault
	<p>Significant movement between the coupling jaw and drawbeam.</p>	<p>Significant movement/play longitudinally due to worn rubber elements.</p>

Inspection method

Visually inspect the rubber elements to ensure that there are no chips, deformations or other indications of wear.

Apply trailer brake, push and pull using the traction vehicle. Measure maximum and minimum distance between the coupling jaw and the washer for the rear rubber element.

Requirements, wear limits, etc.

The movement must not exceed ± 5 mm, i.e. total movement max. 10 mm.

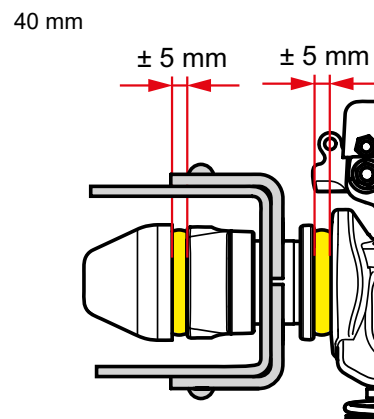
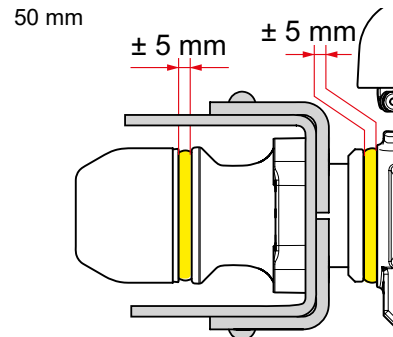



Instructions for rectification



① ② ③

①

In the event of significant movement ($\geq \pm 5$ mm), the rubber elements must be replaced including drawbeam sleeve bushings.

Checkpoint	Symptom	Fault
<p>Coupling jaw for fixed and/or hinged drawbars..</p>	<p>Cotter bent/deformed due to rotation between the nut and coupling jaw. Detected during annual inspection.</p> 	<p>The castellated nut's cotter is defective.</p>
<p>Coupling jaw for fixed and/or articulated drawbars.</p>	<p>The castellated nut does not have a tightening torque/the coupling jaw is loose. Detected during annual inspection.</p>	<p>Castellated nut cotter cut off/missing. The photo shows a cut-off cotter where parts still remain on the horizontal bolt.</p> 

Inspection method

Visually inspect the fitted cotter. Correct locking.

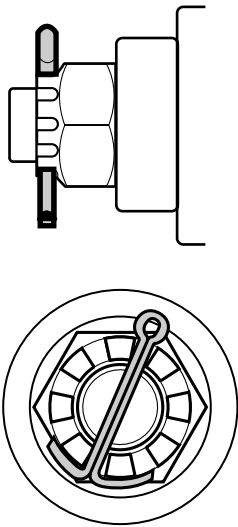

Requirements, wear limits, etc.

The castellated nut must be torque-tightened using torque. The cotter must be properly locked.

RF40, 45, 50, AM	M36x3 M45x3	400 Nm 550 Nm
RF40 B NZ MSD	M45x3	500-600 Nm
RF50 AM INT RF50 AM BR RF50 AM AUS RF50 B AUS MSD RF50 B NZ MSD	M45x3	1500-2000 Nm
RF50 AM JK BR	M45x3	550 Nm

Instructions for rectification



① ② ③

②

Remove the bent/deformed cotter. Check that the castellated nut has the correct tightening torque and lock using a new cotter.

Visually inspect the fitted cotter. Correct locking.

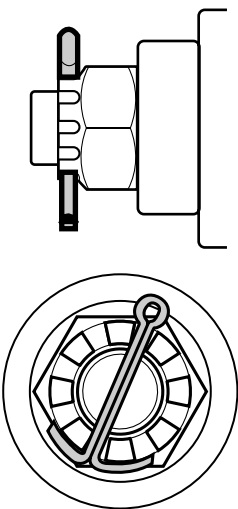

The castellated nut must be torque-tightened using torque. The cotter must be properly locked.

If the castellated nut has come loose, the horizontal bolt's thread may become worn and its sides asymmetrical.

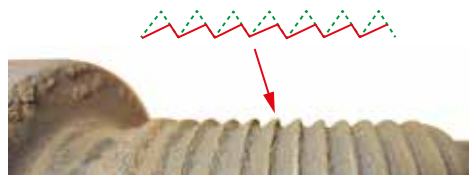

RF40, 45, 50, AM	M36x3 M45x3	400 Nm 550 Nm
RF40 B NZ MSD	M45x3	500-600 Nm
RF50 AM INT RF50 AM BR RF50 AM AUS RF50 B AUS MSD RF50 B NZ MSD	M45x3	1500-2000 Nm
RF50 AM JK BR	M45x3	550 Nm



① ② ③

③

Dismantle the coupling jaw. Visually inspect the horizontal bolt's thread flanks. In the event of a damaged horizontal bolt, replace the coupling jaw.

Coupling



Couplings with V and Dc values



Couplings with only D value

Checkpoint	Symptom	Fault
<p>Attachment package Nut washer couplings.</p>	<p>Cotter bent or cut off. The coupling rotates too easily. Jackknifing damage on endplates, beam, coupling, etc.</p>	<p>The couplings' nut washer under the castellated nut is bent. The coupling has been overloaded.</p>
<p>The drawbeam sleeve's M20 bolts.</p>	<p>No rust residue around bolt head/nut or dust/dirt next to the bolt head or nut.</p>	<p>Bolt is loose or missing.</p>

Inspection method

Visually inspect the fitted cotter. If it is in any way not installed correctly or otherwise affected, it must be removed and the castellated nut fully loosened. Then check the flatness of the nut washer.



Requirements, wear limits, etc.

The cotter must be intact and two of the castellated nut's ports must be in the centre of the cotter hole in the horizontal bolt. The nut washer should be completely flat.

Instructions for rectification







① ② ③

③

Remove the coupling if the cotter is deformed or cut off. If the nut washer is not flat, the coupling must be replaced.

Visually check for any symptoms.

Torque-tighten according to table. There should be no movement between the nut and bolt.

			 Nm
M20 (8.8)	ISO 7042	ISO 7089 min 200 HV	390 Nm
M16 (10.9)	ISO 7042	ISO 7089 min 200 HV	280 Nm
M14 (8.8)	ISO 7042	ISO 7089 min 200 HV	130 Nm

Prescribed tightening torques apply to bolt kits supplied by VBG Group Truck Equipment GMBH.



① ② ③

②

If any bolts are loose or missing, all four bolts must be replaced.

Coupling



Couplings with V and Dc values



Couplings with only D value

Checkpoint	Symptom	Fault
<p>Drawbeam sleeve.</p>	<p>Major radial play between the coupling jaw and drawbeam sleeve, vertically and/or laterally. Reduced comfort, more noise during driving, increased wear to rubber elements.</p>	<p>Drawbeam sleeve bushings worn and/or the diameter of the sleeve too large due to driving with worn bushings.</p>
<p>Rubber elements.</p>	<p>Significant movement between the coupling jaw and drawbeam.</p>	<p>Significant movement/play longitudinally due to worn rubber elements.</p>

Inspection method

Remove the coupling jaw annually. Visually check the plastic bushings and for any indications of wear. Measure the diameter of both ends of the drawbeam sleeve. Measure the coupling jaw's diameter in the middle of the drawbeam sleeve. Measure the coupling jaw horizontal bolt's smallest diameter. During the annual removal of the coupling jaw, the drawbeam must be checked for any reversal deformations and cracking.

Requirements, wear limits, etc.

Compare the measured dimensions with the picture below. Maximum movement vertically and/or sideways may not exceed ± 5 mm measured from the coupling bolt. This movement is measured when the coupling jaw is correctly positioned in the longitudinal direction relative to the drawbeam sleeve and then again without rubber elements fitted.

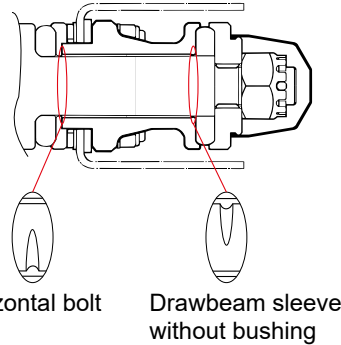

50 mm coupling drawbar

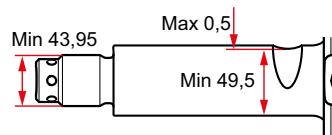
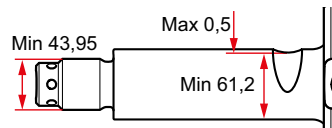

40 mm coupling drawbar

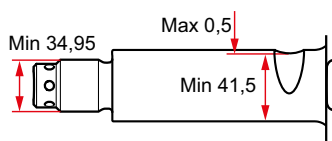
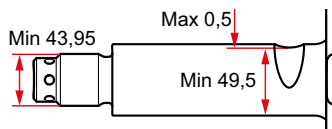

Instructions for rectification



Remove coupling jaw from the drawbeam sleeve. Clean the horizontal bolt and the drawbeam sleeve.

2

In the event of worn bushings, replace these including the rubber elements.



In the event of a damaged horizontal bolt, replace the coupling jaw.

3

If the drawbeam sleeve is damaged, it must be replaced.

Visually inspect the rubber elements. There should be no chips, deformations or other indications of wear. Apply trailer brake, push and pull using the traction vehicle. Measure maximum and minimum distance between the coupling jaw and the washer for the rear rubber element.

The movement must not exceed ± 5 mm, i.e. total movement max. 10 mm.

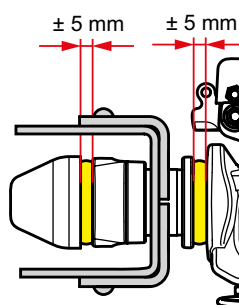

In the event of significant movement ($\geq \pm 5$ mm), the rubber elements must be replaced including drawbeam sleeve bushings.

1

Coupling



Couplings with V and Dc values



Couplings with only D value

Checkpoint	Symptom	Fault
Coupling.	<p>Reduced guidance. Noise while driving. Incorrect height of the drawbar eye's wear on the coupling bolt.</p>	<p>Deformed or broken coupling mouth, deformed or broken during connection or potential jackknifing of the drawbar. Deformed or broken coupling mouth, or dirt /corrosion between coupling mouth and bearing surfaces on bushes.</p>
Coupling mouth.	Coupling mouth dont turn back to central position.	Deformed or broken coupling mouth, or dirt /corrosion between coupling mouth and bearing surfaces on bushes.
Wear plates.		<p>The coupling bolt is not triggered during connection because the wear plate is worn and therefore does not lift the coupling bolt high enough. Also check the drawbar eye's wear; see "Guidelines for inspection of drawbars and drawbar eyes".</p>

Inspection method

Check all functions of the variable coupling mouth, locking in the connected position straight ahead.

Check in particular for any damage arising due to jackknifing, reversing, etc. The coupling can be opened when the coupling mouth is in its normal position or at a maximum angle to its outer positions.

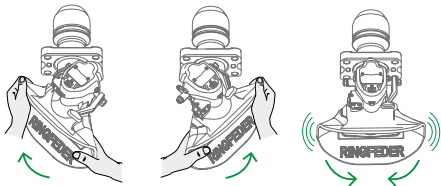

Requirements, wear limits, etc.

No deformations or cracks are permitted. All functions such as coupling mouth locking, recovery, guide arms, etc. must have full functionality.

In the event of damage arising from jackknifing, the horizontal shaft must be carefully examined with respect to bending and any cracks.

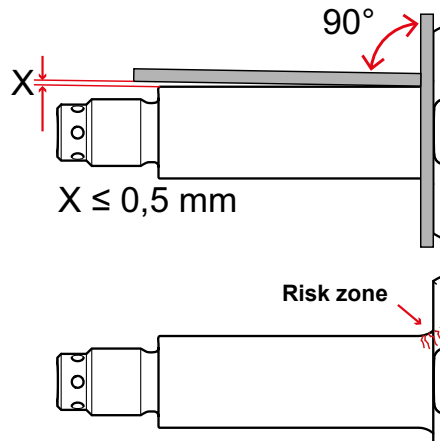

Instructions for rectification



Replace the coupling mouth if it is damaged.

①



If the coupling mouth has been damaged by jackknifing, the coupling should be dismantled and the horizontal shaft checked. If there are cracks, replace the coupling. When the coupling bolt bends more than 0.5 mm from its intended position, replace the coupling.

③

Check all functions of the variable coupling mouth, locking in the connected position straight ahead.

Check in particular for any damage arising due to jackknifing, reversing, etc. The coupling can be opened when the coupling mouth is in its normal position or at a maximum angle to its outer positions.

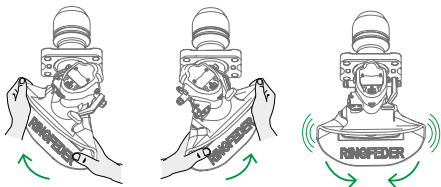

Coupling mouth shall turn back to central position with spring forces.

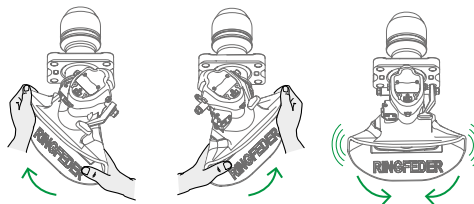

In case of any deformations or cracks on the coupling mouth it must be changed to new.

③

With dirt or corrosion, use Ringfeder oil on the bearing surfaces.

Visually check the height of the wear plate.

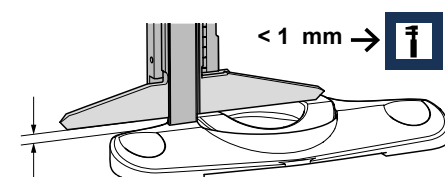
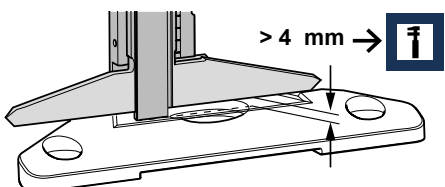

Minimum height according to marking must be achieved.



The wear plate's minimum height is indicated = replace wear plate.

①

Coupling









Couplings with V and Dc values

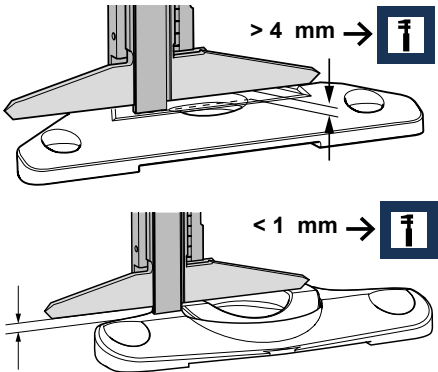

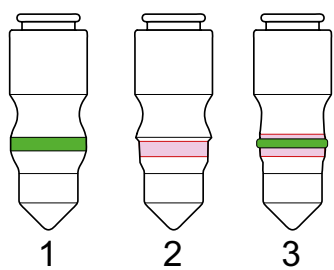
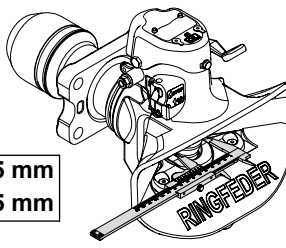
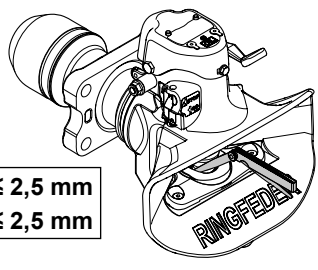
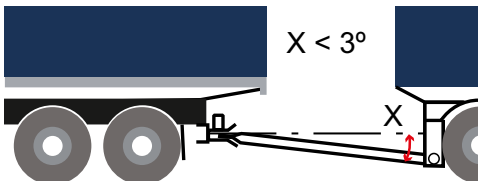
Couplings with only D value

Checkpoint	Symptom	Fault
Wear plates.	Difficult to connect.	If the wear plate has been loose over time, weariness underneath wear plate cause that screws cannot be tightend.
Coupling bolt.	<p>The wear marks are incorrectly positioned on the coupling bolt (not centred over the “coupling bolt’s wear surface for the eye”).</p> <p>Quick wear, which leads to play between the vehicle and trailer; constant jolting between the vehicle and trailer may occur.</p>	The trailer jolts an unusual amount behind the traction vehicle due to significant play between the coupling bolt and the drawbar eye. There will be play when the wear plate is excessively worn.
Coupling bolt. The wear from the drawbar eye on the coupling bolt	<p>The coupling bolt moves up and down slightly when the traction vehicle pushes and pulls at the drawbar.</p> <p>The coupling bolt’s wear/marks from the eye are below the coupling bolt’s biggest diameter.</p> <p>The coupling bolt’s wear/marks from the eye are below and above the coupling bolt’s biggest diameter.</p> <p>Quick wear, which leads to play between the vehicle and trailer; constant jolting between the vehicle and trailer may occur</p>	The coupling bolt’s wear/eye marks are incorrectly positioned on the coupling bolt (not centred over the “coupling bolt’s wear surface for the eye”) due to worn wear plate and/or incorrect drawbar height for coupling.

<p style="text-align: center;">Inspection method</p> <p>Check wear plate underneath.</p>	<p style="text-align: center;">Requirements, wear limits, etc.</p> <p>Tightening torque wear plate, 47 Nm.</p>	<p style="text-align: center;">Instructions for rectification</p> <p> Replace wear plate. ① ② ③ ①</p>
<p>Visually check the height of the wear plate</p> 	<p>Minimum height according to marking must be achieved.</p>	<p> The wear plate's minimum height is indicated = replace wear plate. ① ② ③ ①</p>
<p>Watch out for any vertical movement of the coupling bolt when the vehicle pushes and pulls at the braked trailer. Check the coupling bolt's wear pattern. Picture 1 with the green field in the middle displays the correct wear amount. Picture 2 with the red field indicates a drawbar eye that is too low due to a worn wear plate. Picture 3 shows a drawbar that is connected at the wrong height relative to the coupling, i.e. wear both above and below the coupling bolt's green field.</p> 	<p>There must be no vertical movement of the coupling bolt when the vehicle is pulling and pushing at the braked trailer. There should be no wear outside of what is indicated in coupling bolt picture 1 or the minimum diameters specified in the table below.</p>   	<p> If the wear on the bolt is too low or the wear plate's minimum height is indicated, it must be replaced. ① ② ③ ① When the wear to the eye for the bolt is too great, the drawbar's balancing force will be reduced; the eye must rest firmly in the coupling mouth.</p> <p> If the wear looks the same as for coupling bolt no. 3, the drawbar is at the incorrect height relative to the coupling, in which case its attachments should be rebuilt; the drawbar should be horizontal in the operating position. ①</p> <p> If the bolt is outside of the specified limits in terms of the smallest diameter, the mechanism must be replaced. ① ② ③ ②</p>

Coupling



Checkpoint	Symptom	Fault
Coupling bolt.	Quick wear, which leads to play between the vehicle and trailer; constant jolting between the vehicle and trailer may occur.	The coupling bolt wears out quickly. Significant total play between the vehicle and trailer because the eye's wear ring/ bushing is worn and/or the coupling bolt and its bushings are worn.
	"Rattling" sound from the drawbar eye/the coupling. Quick wear, which leads to play between the vehicle and trailer; constant jolting between the vehicle and trailer may occur.	Worn coupling bolt. Incorrectly balanced drawbar.
Coupling bolt.	The bolt appears to have corroded.	Small cavities on the bolt surface. Poor ground connection with the traction vehicle.

Inspection method

Visually check the drawbar eye's wearing and bushing and measure the diameter of the wearing and bushing. Visually check the coupling bolt and the upper/lower jaw bushing and measure each diameter.

Requirements, wear limits, etc.

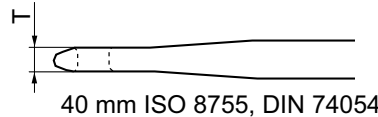
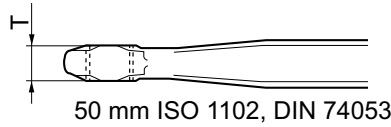
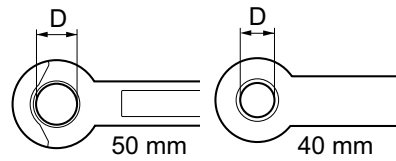

	≤ D (mm)	≥ T (mm)
ISO 50	52	42,5
DIN 40	42	28

Instructions for rectification



Replace components outside of the specified max./min. dimensions.

②

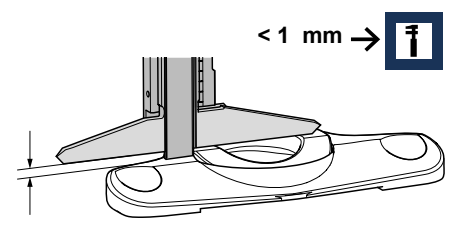
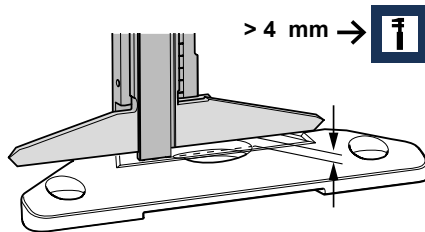
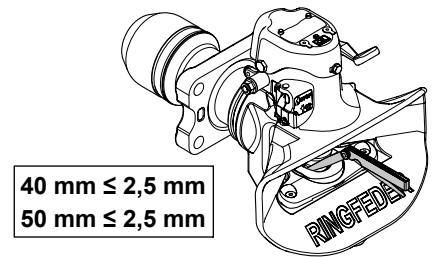
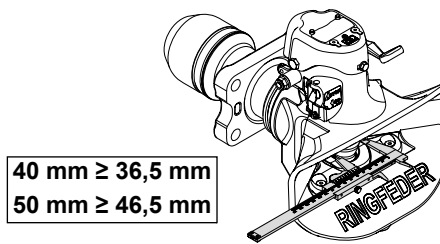

Estimate the support load of a fixed drawbar or from an articulated drawbar.

Fixed drawbar: Support load
2–5 kN (200-500 kg)
Articulated drawbar: Support load
100–500 N (10-50 kg)



If necessary, the support load must be adjusted.

①

Measure any difference in voltage between the traction vehicle and trailer, which are only connected electrically if there is a full load. Measure between the drawbar eye and grounding point for the traction vehicle.





There must be no difference in voltage.



Ensure that the ground connection is correct so that all return current goes via the electric cables.

①

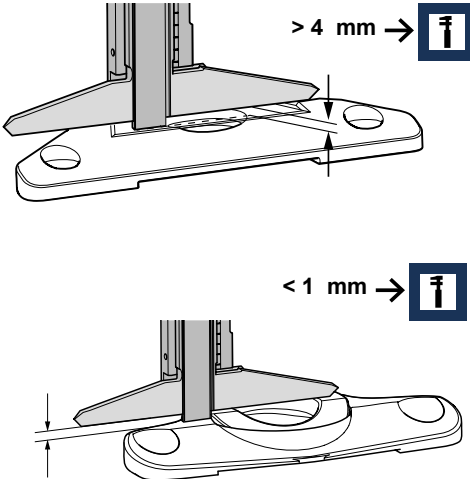
Checkpoint	Symptom	Fault
<p>Coupling Manual coupling</p> 	<p>The coupling bolt does not lock.</p>	<p>The coupling bolt does not move into the locked position during connection because the lower jaw bushing is not completely pressed in or is loose.</p>
<p>Manual coupling</p>	<p>The coupling bolt gets stuck in the open position during connection. Not possible to connect.</p>	<p>The mechanism does not close during connection because the coupling bolt jams.</p>
<p>Manual coupling</p>	<p>The coupling bolt gets stuck in the open position during connection. Not possible to connect. The handle sometimes jams when engaging the coupling bolt. A scraping noise is sometimes heard. Can sometimes be difficult to engage.</p>	<p>The mechanism does not close during connection. The closing springs are damaged.</p>
<p>Manual coupling</p>	<p>Not possible to connect.</p>	<p>The coupling bolt is not triggered. The wear plate is worn.</p>

<p style="text-align: center;">Inspection method</p>	<p style="text-align: center;">Requirements, wear limits, etc.</p>	<p style="text-align: center;">Instructions for rectification</p>
<p>Open and close the coupling. Check the signal pin's position.</p>	<p>The lower jaw bushing must be fully pressed in and must not be loose. The locking pin must assume the locked position.</p>	<p> Replace damaged part(s) such as bushing and/or coupling jaw.</p> <p>① ② ③</p> <p>③</p>
<p>Press up the bolt using a mandrel and check that the bolt moves. If the coupling bolt does not fall under its own weight, attempt to close the coupling by pressing the handle down.</p>	<p>It must be easy to move the bolt up slightly and for it to drop back down under its own weight.</p>	<p> When the lifting arm releases the coupling bolt, it does not fall down under its own weight. Lubricate the mechanism using "VBG MechOil" through the holes and try again.</p> <p>① ② ③</p> <p>③</p>
<p>Open and close the coupling several times and look out for any symptoms.</p>	<p>None of the examples of symptoms listed should occur.</p>	<p> In the event of symptoms, open the mechanism and replace the springs.</p> <p>① ② ③</p> <p>③</p>
<p>In such a case, visually check the height of the wear plate's indication marks.</p>	<p>Minimum height according to marking must be achieved.</p> 	<p> The wear plate's minimum height is indicated = replace wear plate(s).</p> <p>① ② ③</p> <p>①</p>

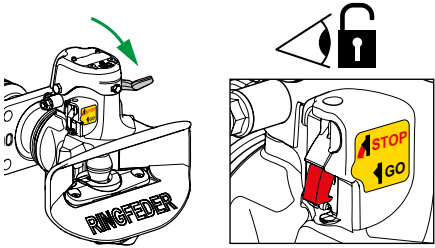
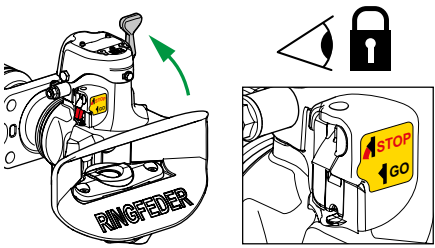
Checkpoint	Symptom	Fault
<p>Signal and locking pin.</p>	<p>The signal pin does not show locked and secured position after this is triggered and in the locked position. The signal pin is not level with the surface of the plastic cover.</p>	<p>The signal pin does not assume the correct position when the bolt goes down; shows open coupling.</p>  <p>Fault indication for locked coupling.</p>
<p>Signal and locking pin.</p>	<p>The signal pin does not show locked and secured position after this is triggered and in the locked position. The signal pin is not level with the surface of the plastic cover.</p>	<p>The signal pin does not assume the correct position after the bolt has engaged; shows closed and secured position.</p>  <p>Fault indication for open coupling.</p>

Inspection method

Push the bolt down using the handle; ensure that the handle matches the picture.

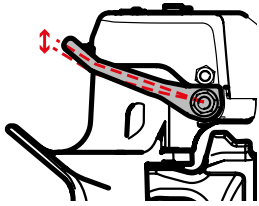

There must be slight play in the handle before the bolt moves up.

Check the signal pin's position.

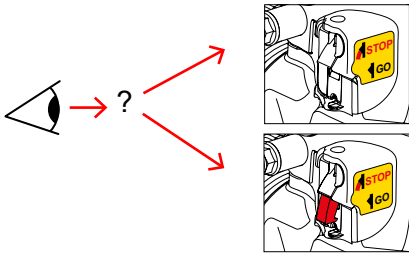

Bleed any actuator. Check that there is slight axial play in the coupling bolt using a mandrel. (The closing spring tension must be overcome.)

Requirements, wear limits, etc.

The signal pin must not be deformed or otherwise put out of order. The coupling bolt, locking pin and signal pin must all slide easily and must not jam.

The signal pin must lie level with the surface when the coupling is closed.

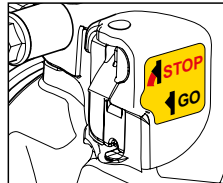

It must be possible to move the coupling bolt up max. 5 mm.

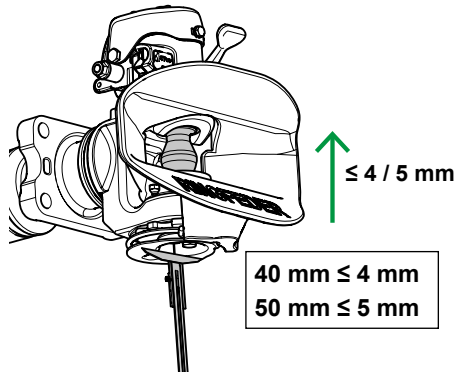

Instructions for rectification



Clean the lower jaw bushing. Lubricate the entire mechanism. Retest the function.



If only the locking pin and the signal pin jam, these must be replaced.

If only the signal pin is deformed, replace it. If the signal/locking pin does not work, the mechanism must be replaced.

Close and open the coupling while watching the signal pin.

The signal pin must move during closing/opening and must be away from the plastic cover when the coupling bolt is in raised position.









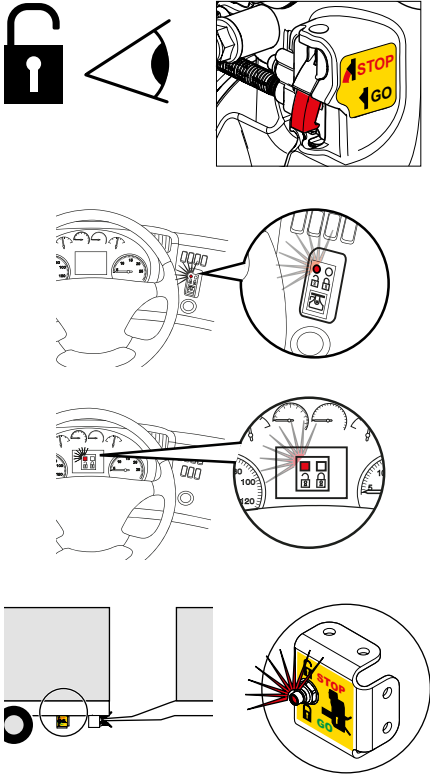
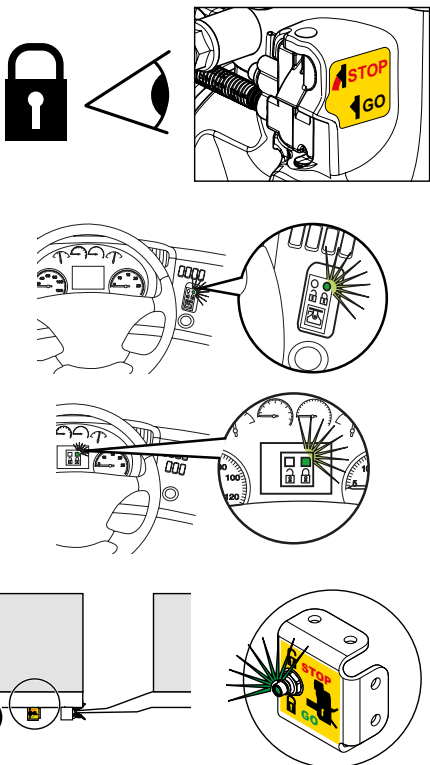



Remove the signal and locking pins and clean other parts.



Fit a new kit containing signal and locking pin, spring and plastic cover.

Checkpoint	Symptom	Fault
<p>Coupling with remote indication</p>	<p>Red lamp dont light when coupling is open.</p>	<p>Red lamp dont light when coupling is open.</p> 
<p>Coupling with remote indication</p>	<p>Green lamp dont light when coupling is closed.</p>	<p>Green lamp dont light when coupling is closed.</p> 

<p style="text-align: center;">Inspection method</p>	<p style="text-align: center;">Requirements, wear limits, etc.</p>	<p style="text-align: center;">Instructions for rectification</p>
<p>Visual check.</p>	<p>Red lamp shall light when signal pin have moved out 3 mm.</p>	<p>  Check connectors so that they are not damaged and that the wiring is not damaged. if so, change unit / item. </p> <p>    </p> <p>  </p>
<p>Visual check.</p>	<p>Green lamp shall light when the locking pin is in the plastic house complete.</p>	<p>  Visually check that the signal pin shows the locked coupling. Check connectors so that they are not damaged and that the wiring is not damaged. if so, change unit / item. </p> <p>    </p> <p>  </p>

Checkpoint	Symptom	Fault
AM coupling	Intermittently operates when the coupling is closed before the eye actuates the coupling bolt Not possible to connect	The coupling bolt is engaged but sometimes the mechanism triggers without the drawbar eye actuating it due to the bolt being jammed
AM coupling	Not possible to connect because the coupling closes when the control valve is switched to closed or when the control kit is disconnected.	The coupling bolt is not engaged.

Inspection method

Check the AM unit visually, especially the plate cover.
Lubricate the mechanism using thin oil, open the mechanism using air and then bleed.
Tap lightly using a hammer in both directions on the mechanism handle.

Requirements, wear limits, etc.

The must be no dents/deformation deeper/higher than 2 mm from nominal surface B. The rivet head in level B may not be damaged or missing.
The coupling must remain open when you tap the handle.

----- = Deformation line

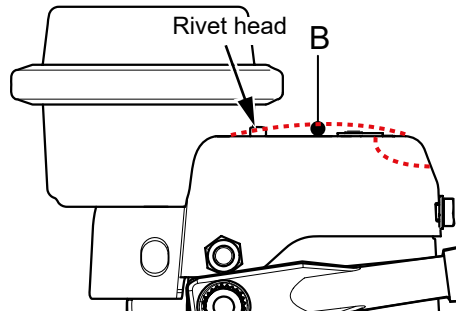

Instructions for rectification



In the event of damage to the AM unit, it must be replaced if the deformation represents a deviation of more than 2 mm or if the rivet is damaged or missing.

①

If the AM unit is undamaged and the coupling still closes when tapped lightly, the mechanism must be replaced.

Try to open using air and to press the handle towards opening and engaging. If the coupling bolt engages, the coupling air pressure and the feed pressure to the control unit must be checked.



The coupling bolt should engage at the minimum pressure of 5.5 bar. The feed pressure should be 5.5 to 8.5 bar.

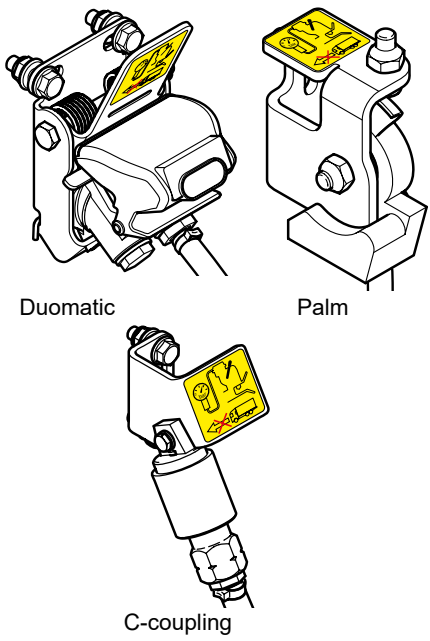

①

Troubleshoot the vehicle if the air pressure is below 5.5 bar. If the vehicle's air pressure is higher than 5.5 bar and engages when the handle is pressed against the opening, the AM unit must be replaced.

<p>Checkpoint</p>	<p>Symptom</p>	<p>Fault</p>
<p>Parking position for air connection.</p>  <p>Duomatic</p> <p>Palm</p> <p>C-coupling</p>	<p>Does not close distinctly.</p>	<p>The control unit/parking position does not drain the air from the AM unit.</p>
<p>AM coupling.</p>	<p>Not possible to connect or disconnect; the coupling opens slowly or not at all.</p>	<p>The coupling does not open or opens very slowly due to reduced air flow or low supply pressure.</p>

<p style="text-align: center;">Inspection method</p> <p>After the air connection is placed in its parking bracket, the coupling bolt is released from the engaged position. Check the closing speed and that the signal pin momentarily assumes the locked position.</p>	<p style="text-align: center;">Requirements, wear limits, etc.</p> <p>The signal pin must show locked and the coupling bolt must quickly assume the locked position</p>	<p style="text-align: center;">Instructions for rectification</p> <p> If there are symptoms, check that there is free drainage when the air connector is placed in its parking bracket.</p> <p>① ② ③</p> <p>③</p>
<p>Check the condition of the hoses. Check the supply pressure to the control valve and the coupling pressure using a manometer.</p>	<p>There must be no kinks or leaks in the hoses or their connections. The feed pressure should be 5.5 to 8.5 bar.</p>	<p> If the vehicle pressure below 5.5 bar, troubleshoot the vehicle. If the pressure is 5.5 bar or higher, the AM unit must be replaced.</p> <p>① ② ③</p> <p>③</p>



Produced in a certified company

VBG GROUP TRUCK EQUIPMENT GMBH · Girmesgath 5 · D-47803 Krefeld
www.ringfeder-rf.com